



## Amplifying Telephone

Product Model: JWAT309

Defend Grade: IP65

Communication System: Analogue

Material: Rolled Steel

Color: Yellow (Optional)



### Technical Parameters

Voltage	AC220V
Standby Work Current	≤1mA
Frequency Response	250~3000 Hz
Ringer Volume	≥80dB(A)
Corrosion Grade	WF2
Ambient Temperature	-30~+60℃
Atmospheric Pressure	80~110KPa
Relative Humidity	≤95%
Lead Hole	2-PG11
Weight	5.8kg
Installation	Wall-mounted



### Application

This Waterproof Telephone Is Very Popular For Tunnels, Mining, Marine, Underground, Metro Stations, Railway Platform, Highway Side, Hotels, Parking Lots, Steel Plants, Chemical Plants, Power Plants And Related Heavy Duty Industrial Application, Etc.



## Features

1. Robust housing, constructed of cold rolled steel with powder coated.
2. Vandal resistant handset with Internal steel lanyard and grommet provides added security for handset cord.
3. Magnetic hook switch with reed switch.
4. Loudspeaker is connected to the telephone, when there is a call coming, the loudspeaker will ring and after 1-7 sounds, the call will connect automatically through the speaker. After the handset is picked up, the call will be through the handset.
5. Optional noise-canceling microphone available.
6. Wall mounted, Simple installation.
7. Weather proof protection IP65.
8. Connection: RJ11 screw terminal pair cable.
9. Multiple color available.
10. Self-made telephone spare part available.
11. CE, FCC, RoHS, ISO9001 compliant..



## Product Dimensions

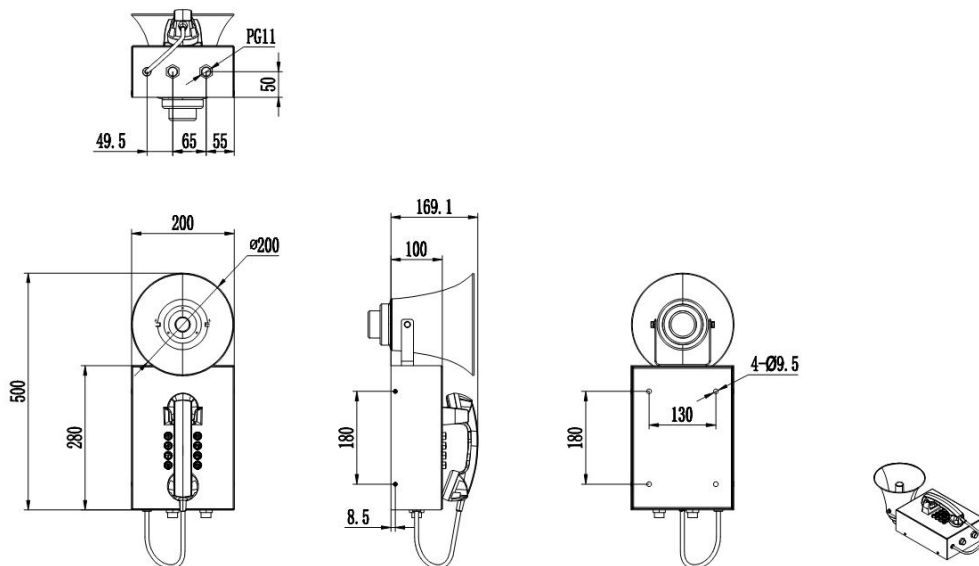

## Package

Unit size: 500\*200\*170(mm)

Packaging materials: Pearl cotton, Carton

Net weight: 5.8 KG

Gross weight: 6 KG



## Service and Support

Under normal use, non-human damage, free **THREE YEAR WARRANTY**.



86-574-58223619



Sales@joiwo.com



<https://www.joiwo.com>



No. 8 Middle Road Guoxiang Bridge Lanjiang Street Yuyao Zhejiang China